

# **Generic Electrofusion User Guide for Field Joining of Polyethylene Gas Piping**

**TR-49**

**2020**

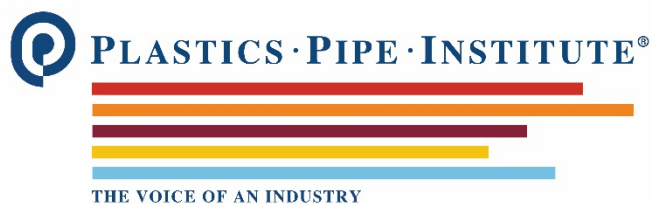

# FOREWORD

This user guide was developed and published with the technical help of the members of the PPI (Plastics Pipe Institute, Inc.). The members have shown their interest in quality products by assisting independent standards-making and user organizations in the development of standards, and also by developing reports on an industry-wide basis to help engineers, code officials, specifying groups, and users.

The purpose of this user guide is to provide important information available to PPI on a particular aspect of polyethylene pipe electrofusion to engineers, users, contractors, code officials, and other interested parties. More detailed information on its purpose and use is provided in the document itself.

This guide has been prepared by PPI as a service of the industry. The information in this report is offered in good faith and believed to be accurate at the time of its preparation, but is offered “as is” without any express or implied warranty, including **WARRANTIES OF MERCHANTABILITY AND FITNESS FOR A PARTICULAR PURPOSE**. Consult the manufacturer for more detailed information about the particular joining procedures to be used with its piping products. Any reference to or testing of a particular proprietary product should not be construed as an endorsement by PPI, which does not endorse the proprietary products or processes of any manufacturer. The information in this report is offered for consideration by industry members in fulfilling their own compliance responsibilities. PPI assumes no responsibility for compliance with applicable laws and regulations.

PPI intends to revise this guide from time to time, in response to comments and suggestions from users of the report. Please send suggestions of improvements to the address below. Information on other publications can be obtained by contacting PPI directly or visiting the web site.

The Plastics Pipe Institute, Inc.

[www.plasticpipe.org](http://www.plasticpipe.org)

This Technical Report, TR-49, was first issued in September 2020.

© 2020 The Plastics Pipe Institute, Inc.

## TABLE OF CONTENTS

Acknowledgments	V
1.0 History	1
2.0 Scope	1
3.0 Introduction	2
3.1. Other Acceptable Fusion Procedures	2
4.0 Safety Notes and Warning Symbols	3
5.0 Jobsite Preparation	4
6.0 Fitting Storage and Handling	4
7.0 Required Tools	5
8.0 Measuring Pipe	7
8.1. Diameter	7
8.2. Pipe Toe-In	8
8.3. Roundness	8
9.0 Pipe Preparation	10
9.1. Cleaning	10
9.2. Scraping/Peeling	11
10.0 Fitting Clamping	15
11.0 Control Box	16
12.0 Power Requirements	17
13.0 Fusion Parameters	18
14.0 Electrofusion Installation Training Procedures	19
14.1. Coupling Installation	19
15.0 Saddle Installation	22
15.1. Clean the Pipe	22
16.0 Installation Inspection Checklist	26
17.0 Joint Inspection/Acceptance Criteria	28
17.1. During Installation:	28
17.2. After Installation:	28
18.0 Assembly Error Examples	29
Frequently Asked Questions	31
Operator Training and Qualification Guidelines	35
Sample Written Review	37

## LIST OF TABLES

Table 1: Standard Pipe Dimensions - Iron Pipe Size (IPS) ASTM D2513	7
Table 2: Standard Pipe Dimensions - Copper Tube Size (CTS) ASTM D2737	8
Table 3: Maximum Out-of-Roundness (IPS/DIPS)	9
Table 4: Input Power Requirements	17
Table 5: Maximum Pipe Square-ness Gap	26

## TABLE OF FIGURES

Figure 1: Submersible pump.....	4
Figure 2: Tape Measure and Pi Tape.....	5
Figure 3: Pipe Marking.....	6
Figure 4: Pipe cutters (rotational, ratcheting, and guillotine style).....	6
Figure 5: Marking and cutting larger diameter pipes.....	7
Figure 6: Roundness Measurement.....	9
Figure 7: Schematic of Cleaned Pipe Areas.....	10
Figure 8: Scraping/Peeling measurement using a caliper.....	12
Figure 9: Pipe Peelers.....	13
Figure 10: Tubing Peelers ( $\geq 2$ IPS).....	13
Figure 11: Examples of serrated type blade scrapers.....	14
Figure 12: Hand Scrapers.....	14
Figure 13: Pipe Alignment and Restraining Clamps.....	15
Figure 14: Integral saddle clamps that remain in place after fusion.....	15
Figure 15: Reusable saddle clamps.....	16
Figure 16: 24-Digit Barcode.....	18
Figure 17: Identification Resistor Pins.....	18
Figure 18: Fusion Time & Voltage Label.....	19
Figure 19: Cut Pipe Ends.....	19
Figure 20: Pipe Cleaning – Steps 2a and 2b.....	20
Figure 21: Stab Depth Markings.....	20
Figure 22: Scrape pipe surface to remove oxidation.....	21
Figure 23: Remark Stab Depth.....	21
Figure 24: Install fitting to stab depth.....	21
Figure 25: Secure the pipe.....	22
Figure 26: Connect to Control Box.....	22
Figure 27: Pipe Wash Areas.....	23
Figure 28: Marked Scraping Area.....	23
Figure 29: Pipe Scraped Area.....	24
Figure 30: Saddle Placement.....	24
Figure 31: Secure Saddle.....	25
Figure 32: Control Box Connection.....	25
Figure 33: Pipe Square-ness Measurement.....	26
Figure 34: Correct.....	27
Figure 35: Incorrect.....	27
Figure 36: Correct.....	27
Figure 37: Short Stab - Incorrect Assembly.....	29
Figure 38: Mis-Stab - Incorrect Assembly.....	29
Figure 39: Mis-Cut - Incorrect Assembly.....	30

## ACKNOWLEDGMENTS

Critical input and review was requested of and provided by gas utility operators, Gas Technology Institute (GTI), Operations Technology Development (OTD) members, and electrofusion fitting and equipment manufacturers.

The following is a list of contributors that provided technical assistance, user input, editorial review, and endorsement of this guide:

Atmos Energy	Palermo Plastics Pipe (P3)
CenterPoint Energy	Plastics Pipe Institute (PPI)
CenterPoint Vectren	Friatec (IPEX)
ConEdison	Georg Fischer Central Plastics LLC
Dominion Energy	Plasson USA
Gas Technology Institute	
Infrasource	
National Grid	
Northeast Gas Association	
Northwest Natural	
One Gas	
Peoples Gas	
Quanta Services	
SoCal Gas	

# Generic Electrofusion User Guide for Field Joining of Polyethylene Gas Piping

## 1.0 HISTORY

Electrofusion joining of PE pressure pipe has been commonly used in North America for over 30 years. ASTM standard specifications for materials (ASTM D3350), performance (ASTM F1055), and installation practice (ASTM F1290) have been in publication for many years. Since each fitting manufacturer may have slightly varying geometrical designs, and each manufacturer is responsible for establishing safe installation temperature limits, it is also common that installation instructions can vary from one manufacturer to another. Although instructions can vary, all fitting designs share some common requirements for installation and all manufacturer's instructions include these same requirements.

A PPI task group was formed in 2017 to examine the differences among the varying joining procedures, to identify similarities in those procedures, and to determine whether there were a sufficient number of common elements to provide a basis for a more uniform, or "generic" joining procedure that could be implemented by pipeline operators for regulated gas applications as required in §192.283 (Plastic pipe, qualifying joining procedures) of C.F.R (Code of Federal Regulations) Title 49.

The result of the task group work, along with input from utility users and industry expertise, is the following technical report, *TR-49 - Generic Electrofusion User Guide for Field Joining of Polyethylene Gas Piping*.

## 2.0 SCOPE

The purpose of this document is to provide background and supporting information related to the common installation practices for electrofusion fittings. This information is intended to be used in support of the development of generic joining procedures and practices. The procedures contained herein are in alignment with the manufacturers procedures that have been qualified by subjecting specimen joints made using this procedure to the tests described in C.F.R Title 49, Part 192, §192.283 (1)(iii) and (2).

This document is applicable for electrofusion joining to modern commercially available PE pipe grades of PE2406, PE2708, PE3408, and PE4710. Legacy materials such as PE2306, PE3406, PE3306, Dupont® Aldyl A, Uponor® Aldyl A, and Driscopipe® 7000 or 8000 pipe materials were not included in the development of this document.

PPI hopes that the inherent value of greater uniformity will provide all the incentive necessary for companies to evaluate this procedure as a first option for electrofusion joining of its PE piping products. Use of this procedure is obviously not mandatory, and every electrofusion fitting producer, pipe producer, and pipeline operator retains the option of developing different procedures for its particular products and pipelines. However, PPI believes that its work in developing this procedure as a candidate for

widespread acceptance throughout the industry will lead to greater efficiency, simplicity, and understanding in this area and promote the use of effective, qualified procedures for electrofusion joining of PE gas pipe.

### 3.0 INTRODUCTION

Electrofusion is widely used in the installation of polyethylene (PE) piping for gas pressure applications. Electrofusion fitting designs vary between manufacturers and historically each manufacturer had developed and qualified its own installation procedure. Slight differences in procedures between manufacturers made it difficult for pipeline operators to qualify persons through appropriate training and experience. Creating a more uniform electrofusion joining guideline for natural gas distribution systems would bring greater consistency to this aspect of the gas pipeline installation, facilitate the pipeline owner's efforts to qualify the procedure, increase efficiencies, and simplify DOT enforcement duties.

Pipe preparation is perhaps the most important and least understood aspect of making a sound electrofusion joint. Improper pipe preparation is overwhelmingly the leading cause of unsuccessful electrofusion joint attempts because the installer may not completely understand the goal of pipe scraping, which is to remove a thin layer of the outer pipe surface (see trouble-shooting section for more details) to expose clean virgin material beneath. Additionally, contamination is the second leading cause of failures. Installers must appreciate the vital need to keep all surfaces of the pipe and the electrofusion absolutely clean and free of contamination or other foreign matter.

Proper installation techniques, installer understanding of and training to these techniques, and effective examination before installation are key to a successful installation. This document provides detailed instructions for each key step to a successful installation, why each step is important, and how to tell if the requirements of each step have been accomplished.



#### 3.1. **Other Acceptable Fusion Procedures**

It must be recognized that there are many different procedures used both currently and historically throughout the world that have been proven to make effective, reliable electrofusion joints. The pipeline operator and every fitting producer retain the option of developing different fusion procedures for its particular products and pipelines. In certain cases, due to operating conditions, weather, or the characteristics of the joining equipment, it may be necessary or even advisable to use another procedure.

#### 4.0 SAFETY NOTES AND WARNING SYMBOLS

Safety notes are included in this manual where appropriate, however this manual does not purport to address all of the safety concerns associated with its use. It is the responsibility of the user of this manual to establish appropriate safety and health practices and to determine the applicability of regulatory limitations prior to use.

Symbols are used throughout this manual to indicate the potential for danger, injury, and/or material damage, and to alert the user of important information related to the fusion process. Symbols indicate that particular attention should be given and that an action is necessary.

Symbol	Meaning
	Attention! – Important Information! Possible danger, damage, risk of unsuccessful fusion or poor fusion quality.
	Best Practice – This symbol is used to indicate an instruction that is considered to be a “best practice”. This practice is recommended and potentially vital to success.
	Prohibited! – This symbol is used to indicate a practice, material, tool, or action that is specifically prohibited in conjunction with instructions in this manual.

- ⚠ Follow company guidelines and safety procedures for grounding/static discharge.**
- ⚠ Electrofusion fittings and equipment are not to be considered “explosion proof”.**
- ⚠ Caution should be exercised when working with generators and other electrical power sources.**
- ⚠ Scraping/peeling tools can have sharp edges. Use with care to avoid injury.**
- ⚠ Tools should be in good working order and inspected before use for wear and/or damage. Damaged or worn tools should not be used until repaired.**
- ⚠ The electrofusion processor and generator should be located out of the excavation, when in a gaseous atmosphere, during the electrofusion operation.**



## 5.0 JOBSITE PREPARATION

All heat fusion joining methods require that there is no water or any other foreign liquids flowing or standing in the pipe that can reach the fusion surfaces. Dewatering of the site or excavation may be required to prevent ground water or other liquids from reaching the fusion and contaminating the surfaces to be joined. Dewatering can be accomplished using portable pumps (Fig.1) in moderate conditions.



**Figure 1: Submersible pump**

Electrofusion fittings can be installed in ambient temperatures as recommended by the manufacturer. A typical qualified temperature range for installation is 14°F minimum to 113°F maximum. Some manufacturers have lower and/or higher temperature limits and will state their qualified range in their technical specifications, contact the fitting manufacturer to verify.

## 6.0 FITTING STORAGE AND HANDLING

Electrofusion fittings are packaged in sealed plastic bags as protection against accumulation of dust, dirt, and contamination. The bag should remain in place during normal handling and should only be removed immediately prior to installation. Fittings are typically boxed to protect against sources of degradation, such as oxidation due to UV exposure over long periods of storage. Surface oxidation can still occur, therefore electrofusion fittings should not be exposed for long periods to direct sunlight. Fittings should always be stored indoors in their original packaging until installation. For transportation until installation, enclosed utility truck storage bins are suitable.

**⚠ Fittings with an unknown storage history or that have been exposed to questionable storage conditions should be evaluated through destructive testing of sample fusions. If fusion quality is shown to be affected, the fittings in question should not be installed.**

Fittings should be inspected for damage before installing to ensure that connection points such as terminal pins have not been damaged from handling, that there is no visible damage to fusion surfaces or heating wires, and that no foreign materials are present on or near the fusion surfaces.

Fittings can be cleaned if incidental contact is made with the fusion surface. A suitable cleaning agent that contains no additives to hinder the fusion process must be used. A 90% or greater concentration of Isopropyl alcohol, with no additional additives except water, is universally accepted as a good cleaning agent. Ensure that wipes are clean before use and do not use wipes on multiple surfaces to avoid picking up and spreading contaminants.

Other cleaning agents, such as acetone, have been evaluated<sup>1</sup> and may be acceptable alternates to Isopropyl alcohol. The fitting manufacturer or local regulations should be consulted in case of questions.

**⚠ DO NOT USE DENATURED ALCOHOL – Denatured alcohols may contain additives that can prevent fusion and should not be used.**

## 7.0 REQUIRED TOOLS

Proper tools are essential to a successful electrofusion installation. Tools include devices for measuring, marking, cutting, scraping, peeling, cleaning, clamping (which includes aligning and securing), re-rounding, and power delivery. At minimum, the following items should be accessible during installation

- **Measuring:** A tape measure, rule, or fitting can be used for measurement of insertion (stab) depth of pipe ends inside a coupling. A circumferential wrap Pi tape for measurement of pipe diameter is also recommended to determine that the pipe diameter is within specified tolerance.



**Figure 2: Tape Measure and Pi Tape**

---

<sup>1</sup> GTI-OTD FINAL REPORT 5.16.a-Project Number 21948 *Solvent Cleaning and PE Joining Procedures*.

- **Marking:** A fast-drying permanent visible marker of contrasting color to the pipe is used to mark the pipe surface. The marker must not contain oils or other ingredients that could accidentally contaminate a prepared pipe surface. Marks are needed to locate insertion depths and to use as a guide for pipe scraping effectiveness.

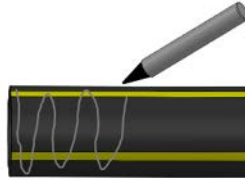

Figure 3: Pipe Marking

**⚠ Markers that are slow-drying or contain oils that could be spread onto fusion surfaces should not be used.**

- **Cutting:** Devices that deliver a relatively clean and square cut ( $\pm 3$  degrees) on the pipe ends are recommended. Square cut pipe ends are important when inserting into electrofusion couplings because a pipe end that is cut with a severe enough angle may not completely extend into the center cold zone or may not cover the heating wires.

Many suitable types of pipe cutters are commercially available that can be used for diameters of 12 inch and smaller (see Figure 4).

**⚠ Use only those devices that are allowed/approved by the pipeline operator in a manner that complies with all safety requirements.**

**⚠ Use caution when cutting pipe that has carried natural gas. Follow company safety guidance for proper tools, grounding, or anti-static discharge measures.**



Figure 4: Pipe cutters (rotational, ratcheting, and guillotine style)

- ✓ For larger diameter pipe, a suitable saw (without lubricants that can be detrimental to the joint) and a guide or guide marks can be used; reciprocating saws, circular saws with a coarse-tooth blade, hot saws, chop saws, and chain saws are commonly used for larger pipes with appropriate safety precautions and personal protective equipment. Cutting marks can be made around the pipe using a 2 inch or wider strap or

encirclement clamp as a guide so that the pipe can then be cut along the line as shown in Figure 5.



**Figure 5: Marking and cutting larger diameter pipes**

## 8.0 MEASURING PIPE

### 8.1. **Diameter**

Electrofusion fittings are designed for use on pipe made to standard diameters in dimensions for Iron Pipe Size (IPS) and Copper Tube Size (CTS). Pipe that is outside of the diameter tolerance band of the appropriate pipe standard should not be used. The following tables include diameters and tolerances from ASTM D2513 and ASTM D2737 and can be used for reference when measuring gas distribution pipe diameter to ensure that is within tolerance.

**Table 1: Standard Pipe Dimensions - Iron Pipe Size (IPS) ASTM D2513**

<b>IRON PIPE SIZE (IPS) ASTM D2513</b>		
Nominal Pipe Size	Nominal Diameter (inches)	Tolerance (+/-)
1/2 IPS	0.840	0.004
3/4 IPS	1.050	0.004
1 IPS	1.315	0.005
1 1/4 IPS	1.660	0.005
1 1/2 IPS	1.900	0.006
2 IPS	2.375	0.006
3 IPS	3.500	0.008
4 IPS	4.500	0.009
6 IPS	6.625	0.011
8 IPS	8.625	0.013
10 IPS	10.750	0.015
12 IPS	12.750	0.017

**Table 2: Standard Pipe Dimensions - Copper Tube Size (CTS) ASTM D2737**

<b>COPPER TUBE SIZE (CTS) ASTM D2737</b>		
Nominal Tubing Size	Nominal Diameter (inches)	Tolerance (+/-)
1/2 CTS	0.625	0.004
3/4 CTS	0.875	0.004
1 CTS	1.125	0.005
1 1/4 CTS	1.375	0.005
1 1/2 CTS	1.625	0.006
2 CTS	2.125	0.006

## 8.2. Pipe Toe-in

A slight reduction in pipe diameter at the end of the pipe is referred to as toe-in. Pipes that are freshly cut and molded fittings generally do not have toe-in. If severe toe-in is present, trimming up to 2 inches off the pipe end will usually remove it.

## 8.3. Roundness

Polyethylene is a flexible material. Although pipe may be round at the time of manufacture, pipe roundness can be affected by a number of conditions to include coiling, storage/stacking, bending, and soil load if buried. The following information can be used to determine if a pipe is suitable for electrofusion joining without the use of re-rounding devices.

The condition of pipe roundness can be expressed in two ways; “out-of-roundness” and “ovality”. While both are referencing the same basic condition, it can sometimes be confusing.

- 8.3.1. Out-of-roundness is the difference in the maximum measured diameter minus the minimum measured diameter. The pipe can be measured with a tape measure or calipers to find the maximum (d1) and minimum (d2) diameter points. The out-of-roundness is calculated as  $d1 - d2$  as measured in the field.

- 8.3.2. Ovality is the difference between the maximum and minimum measured outside diameters expressed as a percentage. Ovality is calculated as  $(d1 - d2) / D_{average} \times 100$ .

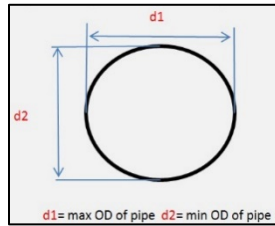

**Figure 6: Roundness Measurement**

Pipe out-of-roundness can have a negative effect on electrofusion joint quality. If the pipe is out-of-round and is not corrected, the amount of gap between the pipe and fitting can be too large for the melt expansion to close and for proper heat transfer to occur between the fitting and the pipe. An out-of-round pipe can also increase the difficulty of sliding (coupling) or clamping (saddle) the fitting onto the pipe.

Most often, 2 IPS and smaller diameter tubing is flexible enough that the coupling and alignment clamps will provide the necessary rounding forces and no other re-rounding device is needed.

For sizes equal to or larger than 3” IPS, re-rounding clamps may be needed on either side of an electrofusion fitting to ensure that the gap between the pipe and fitting is not too large. The table below can be used for guidance when re-rounding clamps are used.

**Table 3: Maximum Out-of-Roundness (IPS/DIPS)**

PIPE SIZE	d1 - d2
3"	.0625 or 1/16"
4"	.0625 or 1/16"
6"	.125 or 1/8"
8"	.125 or 1/8"
10"	.125 or 1/8"
12"	.125 or 1/8"

- 8.3.3. **Pipe scratches, gouges, and damage:** Installation of pipe can cause surface scratches or gouges. Smaller scratches from dragging or normal handling are not problematic and will normally be removed during the pipe preparation process by scraping.

**⚠ Gouges that are deeper than the scrape depth may also require extra attention when scraping the pipe to ensure that any debris or contaminants embedded in the gouges are removed. If the gouge exceeds 10% of the pipe wall thickness**

(refer to Coupling Installation, Sec. 4, p. 17), that pipe section should be cut out and replaced to maintain the maximum pressure rating of the pipe.

- ⚠ Hydrocarbon contamination of PE pipe can result in reduced heat fusion joint strength. Do not attempt to electrofuse to pipe that has been permeated by heavy hydrocarbons at the external surface of the pipe area being fused. Refer to ASTM D2513 Appendix X.1 for guidance on joining PE pipe that is known to have hydrocarbon permeation.

## 9.0 PIPE PREPARATION

### 9.1. **Cleaning**

1. Clean the pipe beyond the area to be scraped with clean water<sup>2</sup> without soap to remove dirt, mud, or other debris. Soaps should not be used because it may contain surfactants or wetting agents that could be detrimental the fusion process.
2. Clean the pipe for a length far enough beyond the area to be fused to ensure that remaining debris on the pipe surface will not be transferred to the area to be prepared during handling.
3. Inspect the cleaned pipe surface for gouges or embedded debris such as rocks that might damage scraping and peeling blades.
4. Next, clean an area approximately twice as long as the area to be scraped with 90% or greater isopropyl alcohol.

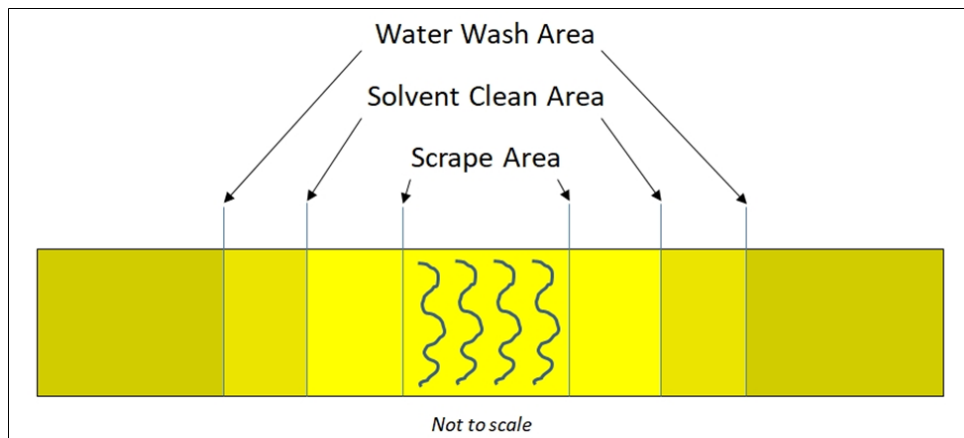

**Figure 7: Schematic of Cleaned Pipe Areas**

NOTE 1: Other cleaning agents (such as acetone) may be suitable. Refer to local regulations for environmental and health effects.

<sup>2</sup> At installation temperatures at or below freezing, a solvent may be used in place of water for the initial cleaning.

## 9.2. Scraping/Peeling

Pipe preparation is perhaps the most important and least understood aspect of making a sound electrofusion joint. Improper pipe preparation is overwhelmingly the leading cause of unsuccessful electrofusion joint attempts because the installer may not completely understand the goal of pipe scraping, which is to remove a thin layer of the outer pipe surface (see trouble-shooting section for more details) to expose clean virgin material beneath.

Pipe surfaces exhibit surface oxidation from the extrusion process, transportation, and outdoor exposure. Surface oxidation is a normal chemical reaction that results in a physical change to the molecular structure of the polymer chains on the pipe surface. Oxidation acts as a physical barrier and therefore those surfaces cannot be heat fused. Simply roughing the pipe surface is not sufficient. In order to achieve fusion, this layer must be removed. Even new pipe must be properly scraped and prepared before a fusion will be successful.

NOTE 2: The pipe preparation method discussed in this guide and references to “peeling” or “peelers” refers to methods of removing the outer surface of the PE pipes. It should not be confused with commercial products designated as “peelable pipes” which contain a removable outer layer. While peelable pipe is suitable for use with electrofusion, the pipe preparation methods discussed in this guide and references to “peeling” or “peelers” are not related to the use of peelable pipe.

The outer oxidation layer on a pipe surface is very thin. It does not increase in depth of more than a few thousandths of an inch even over long periods of outdoor exposure, so regardless of the amount of time the pipe has been stored before scraping, the scraping depth requirement is the same. An adequate minimum amount of material that must be removed is just seven thousandths of an inch (.007” or 7 mils). That thickness is approximately the same as two sheets of ordinary paper.

Pipe preparation tools should be inspected at each use to ensure that they are performing as intended. Cutting blades can dull quickly as they peel pipe. Measurement of material thickness of peeled ribbon can be helpful to determine if tools are working properly. The figure below shows a caliper being used to measure a plastic peel ribbon. The 0.008 inch thickness indicates that the tool is working properly. Preparation tools should be cleaned before each use to remove any dirt, oils, or other residues from parts that will contact the pipe surface.





Figure 8: Scraping/Peeling measurement using a caliper

- ⚠ **Sand paper, emery cloth, or other abrasives should never be used to prepare a pipe surface for electrofusion. Abrasives have been proven to be ineffective for electrofusion because they don't adequately remove material, they can redistribute contaminants on the surfaces, and because they can leave behind a grit residue that forms another barrier that will also prevent fusion.**
  
- ✔ There are many tools that can be used for pipe preparation, however there are differences in operation that should be considered, differences in appearance of the pipe surface after use, and care must be used depending on the type of tool selected. The only tools suitable for use for pipe surface preparation are those that are specifically designed and qualified for electrofusion scraping and peeling.

### 9.2.1. Peelers

Examples of acceptable tools that “peel” the pipe surface to a controlled depth are most commonly referred to as “peelers” and are shown below.



Figure 9: Pipe Peelers

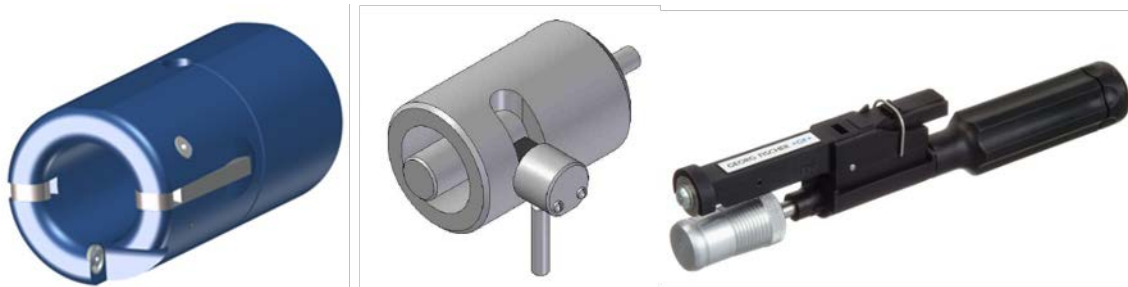

Figure 10: Tubing Peelers ( $\geq 2$  IPS)

### 9.2.2. Scrapers

Tools with serrated blades are also available; these tools physically scrape the pipe surface by pulling the serrated blade across the pipe in a perpendicular position to the pipe. Although these tools can be used satisfactorily for pipe preparation, it is important to know that serrated blades sometimes mask the pipe surface by leaving behind score marks that make it difficult to visually tell if all of the original surface material has been removed. Additionally, if a pipe surface with serrations becomes dirty or contaminated, it may not be reliably cleaned with a solvent and wipe due to the serrations trapping and retaining material.



Figure 11: Examples of serrated type blade scrapers

9.2.3. A third type of tool is referred to as a “hand scraper”. **These scrapers are generally not recommended** when peelers and scrapers are commercially available due to inconsistent surface preparation and difficulty in mastering skills required for uniform surface preparation, however they can be used effectively. As a best practice, they should only be used in situations where confined working space or pipe scratches or gouges require a hand tool.

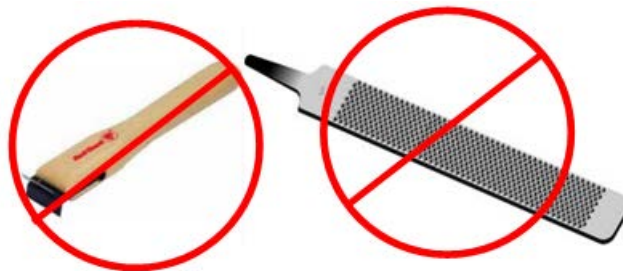

Figure 12: Hand Scrapers

**⚠ Wood rasps and metal files are not acceptable scraping tools.**

✔ It is strongly recommended that, no matter what type of tool is used, witness marks should be made on the pipe surface with a permanent marker prior to scraping. Some reviews have shown that markers can penetrate the pipe surface so any marking that remains after scraping is clear evidence to the user that areas were missed or that more scraping is required.

10.0 FITTING CLAMPING

Electrofusion fittings generate significant pressures from thermal expansion during the melt phase of the fusion process. This melt pressure is an integral part of the fusion process and a designed function of the fitting and fusion parameter. Polyethylene is also a thermoplastic that softens when heated. As a result, it is recommended that all electrofusion fittings should be installed with the use of alignment and restraining clamps or devices.

Couplings use clamps that restrain the pipe ends from moving and keep the pipes in alignment. Some coupling clamp designs when placed on either side of the fitting also serve to round the pipe. The pipe and coupling must be properly aligned and supported in a stress-free condition for fusion and cooling.



**Figure 13: Pipe Alignment and Restraining Clamps**

Saddle type fittings require clamps to secure the fitting to the main to prevent movement, restrain against generated melt pressure, and in some cases to form the fitting to the contour of the main. Saddles are designed to be used with a particular clamping device. Clamping devices are typically not interchangeable from one fitting design or main size to another. In some cases clamping devices may be a part of the fitting in the form of nylon straps or plastic clamps that bolt to the fitting (commonly referred to as under-parts). Straps and underparts are typically intended to remain in place after fusion.

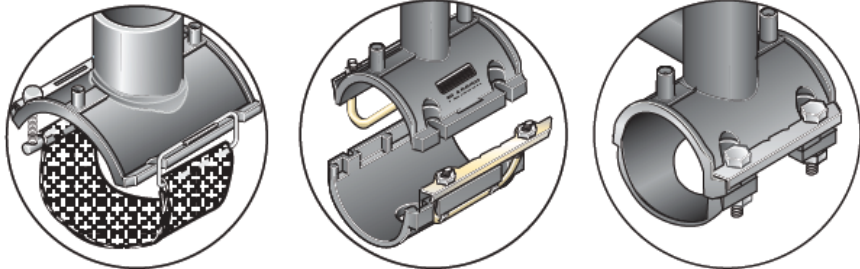

**Figure 14: Integral saddle clamps that remain in place after fusion**

Some other designs include a clamp that is re-usable and is removed after the fitting has cooled.

**⚠ Alignment and restraining clamps need to be inspected for excessive wear or defects.**

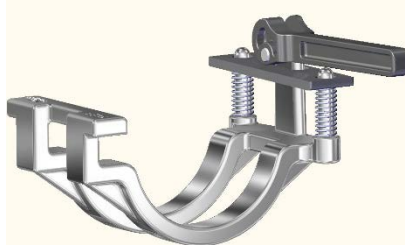

**Figure 15: Reusable saddle clamps**

## 11.0 CONTROL BOX

Electrofusion control boxes, sometimes referred to as processors, perform vital functions during the fusion process. The control box provides carefully regulated voltage for the required fusion time to input the designed energy necessary for fusion. The control box performs basic checks prior to the beginning the fusion to verify that the fitting coil has continuity, that the coil resistance matches the barcode information, and that the voltage being supplied is sufficient. During the fusion process, the control box also monitors the power being supplied to the fitting and can detect certain assembly or fitting errors such as shorted heating coils or short-stabbed pipe ends.

When using the fitting barcode, the control box checks the ambient air temperature and automatically adjusts the fusion time for ambient temperature effects if the fitting barcode requires.

The control box will terminate a fusion process when any defined protocol is out of range and will display an error message. Most control boxes have a list of error message meanings affixed to the unit that can be referred to if an error occurs. A record of each fusion, as well as the result of the fusion cycle, is stored in a downloadable memory.

The control box manufacturer recommends regular calibration intervals, typically every 2 years, to ensure that all monitored parameters are measured accurately and the control box is functioning normally. Units that are past their calibration interval will normally alert the operator at power-up, but will continue to function when acknowledged.

**⚠ It is not recommended that units continue to be used beyond their calibration period.**

12.0 POWER REQUIREMENTS

Control boxes are typically available in 110v or 220v versions. The control box monitors the energy input from the power source to ensure that fluctuations from the generator are within designed tolerances and alerts the installer when parameters fall out of range. Control boxes are typically tolerant to small fluctuations in input voltage or frequency, however not all generators or inverters are equal. Generators frequently are the cause of intermittent errors, when the assembly is known to have been completed correctly. It is important to ensure that the power supply is in good working order and capable of supplying the required energy for the fitting being fused.

Each electrofusion fitting has an integral heating coil that requires a defined amount of energy input to achieve the designed results. Heating coils are engineered specifically for a fitting size or configuration and power requirements will vary from one manufacturer to another for the same size fitting. The fitting manufacturer can provide specific requirements for its particular products, but the table below can be used as a guide for most fittings that are commonly available.

**Table 4: Input Power Requirements**

<b>INPUT POWER REQUIREMENTS</b>					
<b>FITTING TYPE</b>	<b>FITTING SIZE</b>	<b>GENERATOR MINIMUM</b>	<b>BREAKER MINIMUM 110v / 220v</b>	<b>EXTENSION CORD GAGE (25 ft.)</b>	<b>EXTENSION CORD GAGE (50 ft.)</b>
SOCKET	1/2" to 2"	2.5 kVA	15 / 15 AMP	#10/3	#8/3
SOCKET	3" to 12"	5 kVA	30 / 20 AMP	#10/3	#8/3
SADDLE	ALL	2.5 kVa	15 / 15 AMP	#10/3	#8/3

Extension cords can be used, however the wire gage should not be less than that shown in the table above for the applicable maximum length.

Consult the control box manufacturer for further details on recommended extension cords, pigtails, generators or inverter needs.

Load tests can be performed on power supply equipment to verify output and duty cycle.

### 13.0 FUSION PARAMETERS

Fusion parameters such as fusion time, voltage, and cooling time, can be entered into the control box by various means.

- All electrofusion fittings have a fusion barcode attached that contains all of the information needed by the control box to perform the fusion process. Barcodes contain additional information about the fitting manufacturer, fitting resistance, and temperature correction values if required by the fitting manufacturer.
  - Codes are displayed on the fitting label in an interleaved barcode format that can be read by a barcode wand or hand-held scanner.
  - The 24-digit numerical value is also printed on the label, either directly above or below the barcode that can be entered into the control box in the event that the code cannot be scanned.



**Figure 16: 24-Digit Barcode**

- Identification resistors are supplied in some fitting designs that can be read by a compatible control box to automatically set the fusion time, voltage, and cooling time. The resistor pin is usually identified by a colored insert in the center of the pin that can be matched to a colored end of the control box cable.

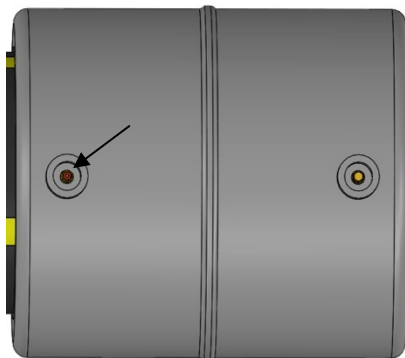

**Figure 17: Identification Resistor Pins**

- Manual entry of fusion time and voltage entry may be possible if printed on the fitting label. The fusion time is typically preceded by the word “WELD” or “FUSE” and displayed in seconds. The voltage is displayed and followed by “V”.

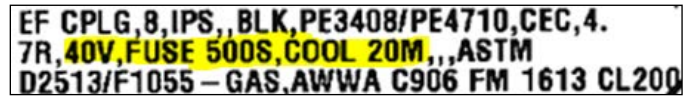

Figure 18: Fusion Time & Voltage Label

## 14.0 ELECTROFUSION INSTALLATION TRAINING PROCEDURES

Preamble: It is important to note that the cleaning, scraping, assembly and fusion steps should be performed promptly in succession, for any type of fitting being installed. Prompt execution of these steps will minimize the chances of contamination on the fusion surfaces of the pipe and fitting.

### 14.1. COUPLING INSTALLATION

1. Cut the pipe ends (after cleaning first if necessary) squarely and evenly to remove any toe-in.

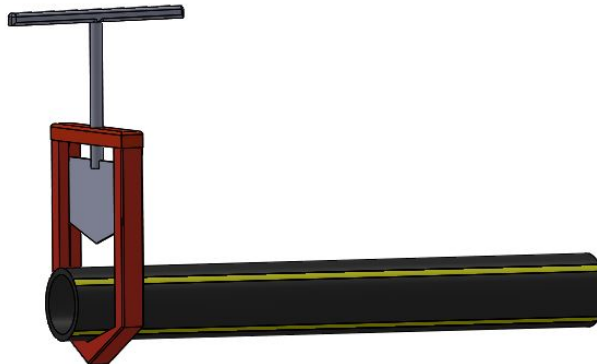
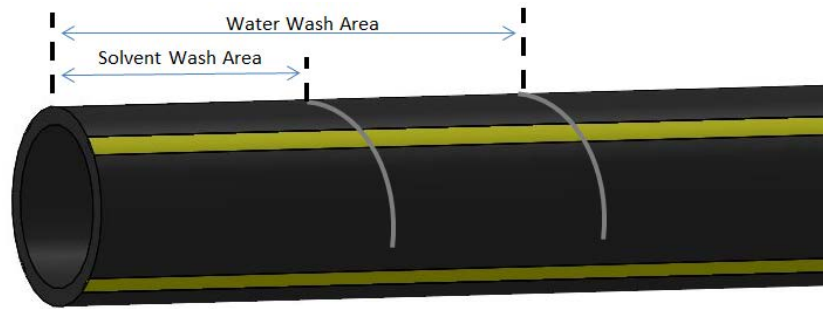

Figure 19: Cut Pipe Ends

2. Clean the pipe ends inside and out to remove dirt, mud, and other debris prior to scraping.
  - a. Clean water (no soap) can be used for initial cleaning of pipe surfaces prior to scraping. Clean the pipe for a length far enough beyond the area to be fused to ensure that remaining debris on the pipe surface will not be transferred to the area to be prepared during handling. Dry with a single-use clean cotton towel or disposable paper towel.
  - b. Solvent-clean the pipe with 90% or greater isopropyl alcohol using a one-time use pre-saturated wipe or single use clean cotton towel or disposable paper towel (exceeding area to be scraped, but within the water-washed area). See Figure below and the Pipe Preparation section for more details.





**Figure 20: Pipe Cleaning – Steps 2a and 2b**

3. Measure and mark the stab depth on the pipe ends. If stab depth marks are not indicated on the outside of the coupling, measure the total length of the coupling to be installed and make a mark on both pipe ends equal to  $\frac{1}{2}$  the length of the coupling. This mark is used as visual indication by the installer of the minimum length that needs to be scraped and that the pipe ends are correctly inserted to the center of the coupler. Check the pipe surface for any embedded debris that may cause damage to scraping tools, and once more make sure that the outer pipe surface is clean and free of any dirt or mud that could re-contaminate the scraped pipe surfaces. Mark the entire pipe surface to be scraped with longitudinal and/or circumferential lines.

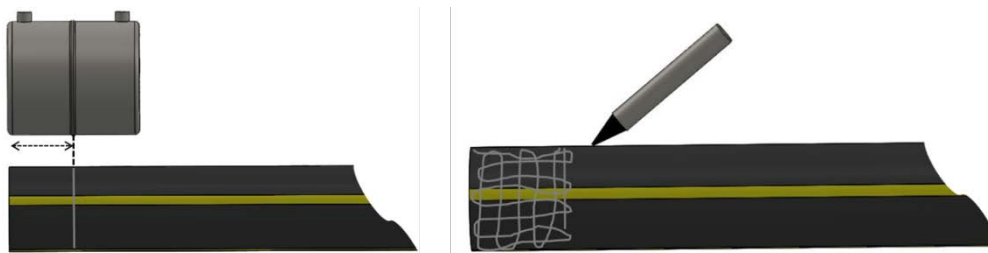

**Figure 21: Stab Depth Markings**

4. Scrape the outside of the pipe surface to remove oxidation and other contaminants. Scrape for a distance slightly longer than the stab depth so that the scraped area is visible beyond the coupling after assembly. Use an appropriate scraping/peeling tool as described in the PIPE PREPARATION section of this guide. Scrape the pipe surface until the outer layer or “skin”, at least .007” thick, of the pipe has been removed to expose a clean, virgin pipe material. If using a peeling tool, periodically break the ribbon to prevent it from wrapping around the pipe. Continue scraping/peeling to remove longitudinal or circumferential markings made in step 3. Inspect the entire scraped area to ensure total scraping coverage.

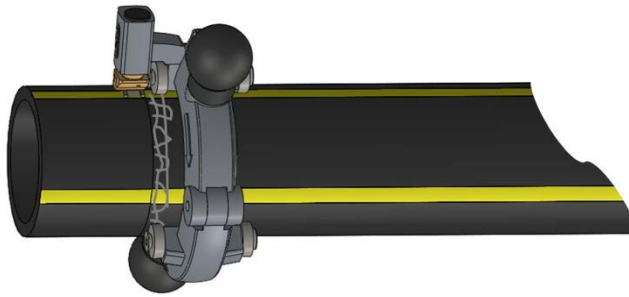

**Figure 22: Scrape pipe surface to remove oxidation**

5. Remark the stab depth. Avoid touching the scraped pipe surface or the inside of the coupling as body oils and other contaminants can affect fusion joint performance. Optionally, clean thoroughly with 90% or greater isopropyl alcohol using a one-time use pre-saturated wipe or single use clean cotton towel or disposable paper towel. Allow to dry before assembling. Do not use alcohol with any additives other than water.

**⚠ CAUTION: Avoid all possible recontamination of the prepared surface.**

**⚠ Do not use Denatured Alcohol.**



**Figure 23: Remark Stab Depth**

6. Remove coupling from plastic bag and immediately slide the coupling over the scraped pipe ends to the stab depth markings. Fitting fusion surfaces can be cleaned with 90% or greater isopropyl alcohol using a single-use pre-saturated wipe or single-use low lint clean towel. Allow to dry before assembling.



**Figure 24: Install fitting to stab depth**

7. Clamp the pipe ends to align and secure the assembly. Verify alignment and that no stress is exerted on the assembly. Make adjustments if necessary and re-secure.

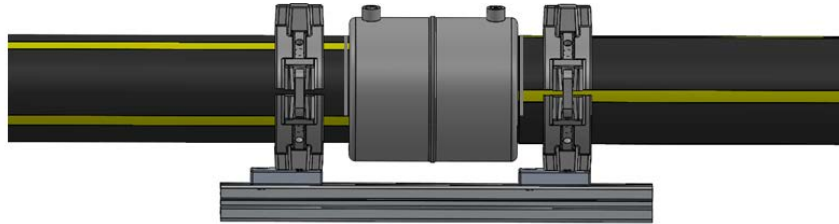

**Figure 25: Secure the pipe**

8. Connect the fitting to the control box, enter the fusion parameters, and fuse the joint. See “Fusion Parameter” section for details.

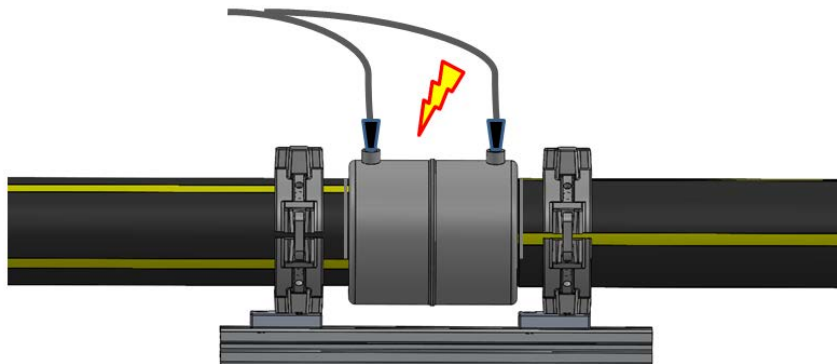

**Figure 26: Connect to Control Box**

9. Allow the fused fitting and pipe assembly to remain undisturbed for the minimum recommended cooling time.

**⚠ Cooling is a vital part of the fusion process. Proper cooling and rough handling times must be observed. See “clamping” section of this guide for further details.**

## 15.0 SADDLE INSTALLATION

### 15.1. **Clean the pipe**

1. Clean the pipe to remove dirt, mud, and other debris.
  - a. Clean water (no soap) can be used for initial cleaning of pipe surfaces prior to scraping. Clean the pipe for a length far enough beyond the area to be fused to ensure that remaining debris on the pipe surface will not be transferred to the area to be prepared during handling. Dry with a single-use clean cotton towel or disposable paper towel.

- b. Next, solvent clean a smaller area of the pipe with 90% or greater isopropyl alcohol using a single-use pre-saturated wipe or single-use clean cotton towel or disposable paper towel (exceeding the area to be scraped, but within the water-washed area). See Figure below and the Pipe Preparation section for more details.

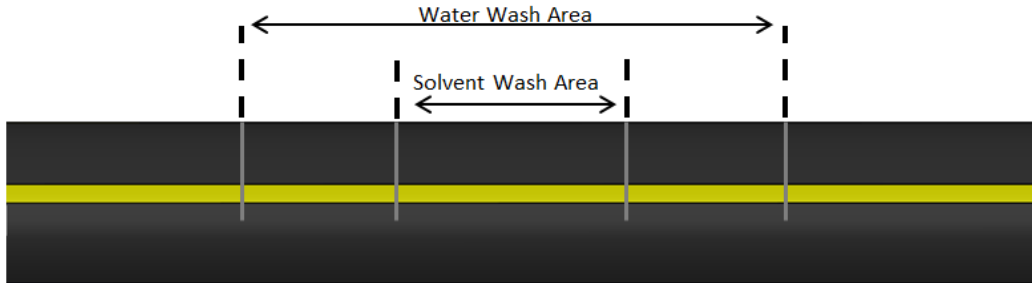

**Figure 27: Pipe Wash Areas**

2. Mark the area on the pipe where the saddle is to be installed. This mark is used by the installer to indicate the approximate size of the area to be prepared. Check the pipe surface for any embedded debris that may cause damage to scraping tools, and once more make sure that the outer pipe surface is clean and free of any dirt or mud that could contaminate the scraped pipe surface. Mark the entire pipe surface to be scraped with longitudinal and/or circumferential lines.

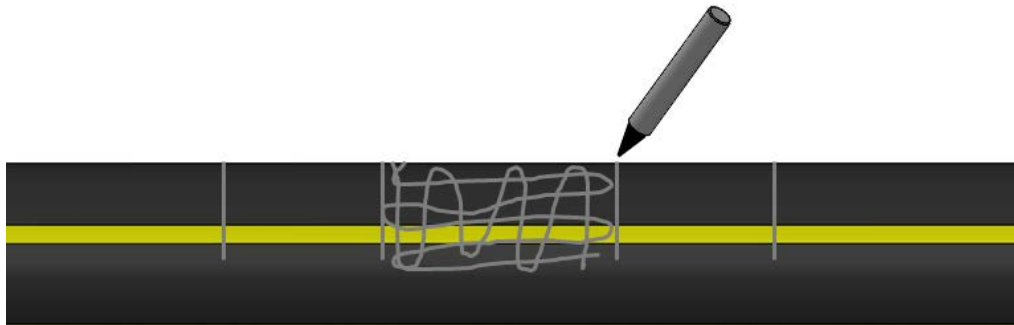

**Figure 28: Marked Scraping Area**

3. Scrape the outside of the pipe surface to remove oxidation and other contaminants. Use an appropriate scraping tool as described in the PIPE PREPARATION section of this guide. Scrape the pipe surface until the outer layer or "skin", at least .007" thick, of the pipe has been removed to expose a clean, virgin pipe material. . If using a peeling tool, periodically break the ribbon to prevent it from wrapping around the pipe. Remove longitudinal or circumferential markings made in step 3. Inspect the entire scraped area to ensure total scraping coverage.

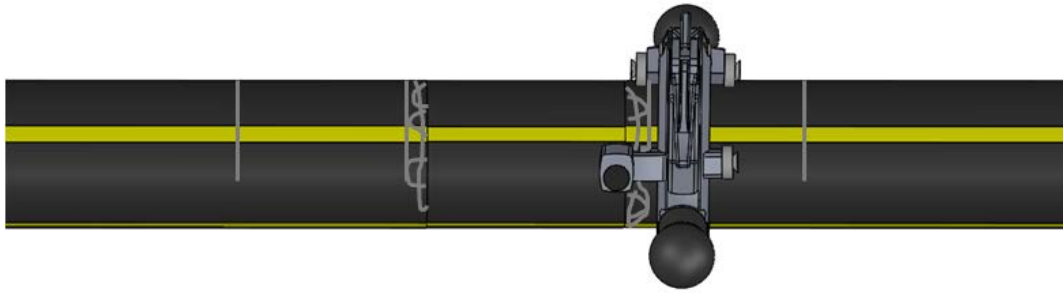

**Figure 29: Pipe Scraped Area**

4. Avoid touching the scraped pipe surface or the fusion surface of the saddle as body oils and other contaminants can affect fusion joint performance. Optionally, clean thoroughly with 90% or greater isopropyl alcohol using a one-time use pre-saturated wipe or single use clean cotton towel or disposable paper towel. Allow to dry before assembling. Do not use alcohol with any additives other than water.

**⚠ CAUTION: Avoid all possible recontamination of the prepared surface.**

**⚠ Do not use Denatured Alcohol.**

5. Remove saddle from bag and immediately place the saddle over the scraped pipe surface. Ensure that the fitting fusion surface is only in contact with the scraped pipe surface. Fitting fusion surfaces can be cleaned with 90% or greater isopropyl alcohol using a single-use pre-saturated wipe or single-use low lint clean towel. Allow to dry before assembling.

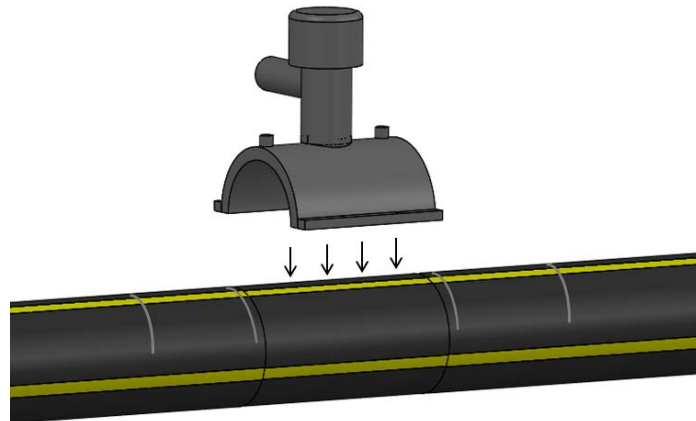

**Figure 30: Saddle Placement**

6. Secure the saddle-to-pipe assembly with the appropriate clamping mechanism required by the fitting manufacturer. If bolts are used in the clamping device, make sure they are tightened in the proper sequence and the required amount. See “clamping” section of this guide for further details.

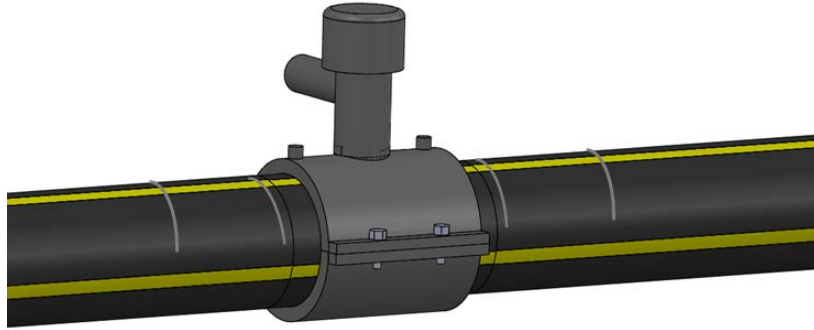

Figure 31: Secure Saddle

**⚠ Use only the clamps provided or required by the fitting manufacturer. Clamps from one manufacturer's fitting are not interchangeable with another's.**

7. Connect the fitting to the control box, enter the fusion parameters, and fuse the joint. See "Fusion Parameter" section for details.

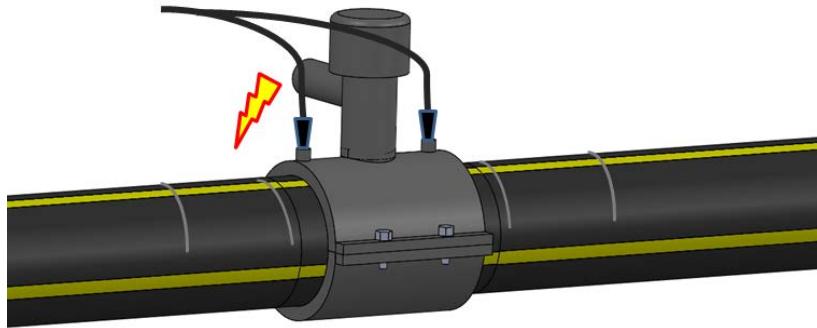

Figure 32: Control Box Connection

8. Allow the fused fitting and pipe assembly to remain undisturbed for the minimum recommended cooling time.

**⚠ Cooling is a vital part of the fusion process. Proper cooling and rough handling times must be observed.**

16.0 INSTALLATION INSPECTION CHECKLIST

- SQUARE CUT ( $\pm 3$  Degrees)

The square-ness of the cut can be checked if needed by placing a square at the end of the pipe at its longest point and measuring the resulting gap between the square and shortest point of the cut. The table below indicates the resulting maximum measured gap when the cut angle is approximately 3 degrees from square.

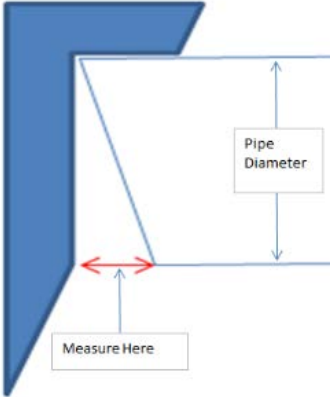

Figure 33: Pipe Square-ness Measurement

Table 5: Maximum Pipe Square-ness Gap

Pipe or tubing size	Maximum gap between square and pipe end to result in approximately 3 degree angled cut
1 1/2 & 2 IPS	1/8"
4 IPS	1/4"
8 IPS	1/2"
12 IPS	5/8"



- SCRAPING

A properly scraped pipe has a thin outer layer of the pipe surface removed to expose clean virgin PE material for fusion. Visual indicators can be very helpful to ensure that all of the surface has been scraped, and that an adequate amount has been removed.

Marking the pipe surface with a permanent marker is a simple and effective step. Using the pipe print line as a depth indicator is also useful.



**Figure 34: Correct**



**INCORRECT!** Not enough material removed, marks still visible.

**Figure 35: Incorrect**

- ASSEMBLY/ALIGNMENT/RESTRAINT

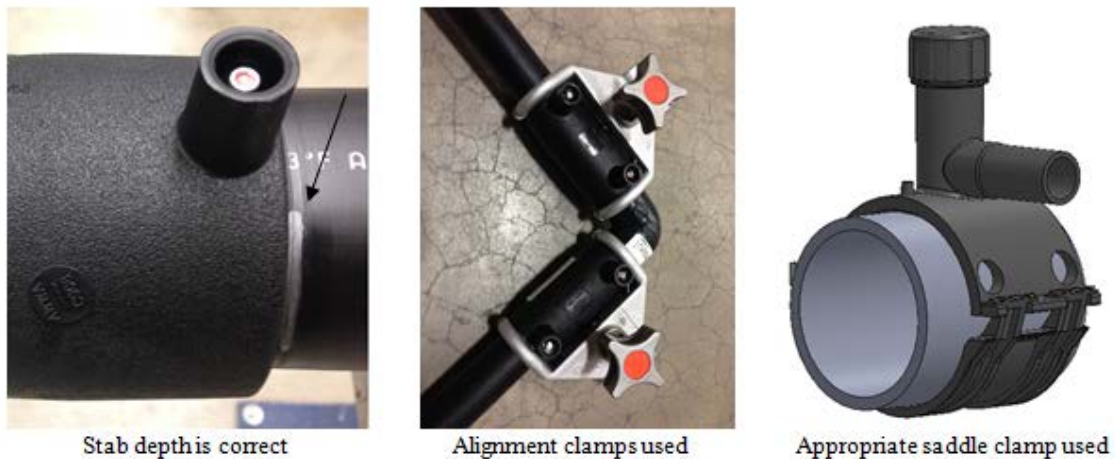

**Figure 36: Correct**



- **FUSION**
  - Ensure that the generator or power source is adequately sized for the fitting being fused.
  - Ensure that the power source has an adequate supply of fuel to complete the fusion cycle.
  - Ensure that any extension cords are appropriately sized for the fitting being fused.
  
- **COOLING**
  - At minimum, mark the time on or near the fitting to indicate when the minimum cooling time has elapsed. This will prevent inadvertent movement or removal of the assembly and/or clamps.
  - Additional information to be marked may include operator identification, control box and fusion record number, or other installer or inspector information.

## 17.0 JOINT INSPECTION/ACCEPTANCE CRITERIA

Inspection of electrofusion joints can only determine what is visible externally after the fusion has taken place. Quality assurance of the fusion joint before placing into service is accomplished during installation by several methods.

### 17.1. **During installation:**

- A trained and qualified installer performed the installation.
- Adherence to installation instructions ensured proper pipe preparation was accomplished.
- Avoidance of the introduction of contamination on the prepared pipe and fitting surfaces was ensured by pre-washing and solvent cleaning.
- Scraping/peeling tools were inspected, cleaned, and in good working order.
- Peeling ribbons were measured and inspected for adequate peeling depth.
- Witness marks on the pipe surface were completely removed by scraping/peeling.
- Cleaning, scraping/peeling, fitting assembly, and fusion steps were performed in a sequence without interruption.
- The fitting was properly clamped and aligned during the fusion and cooling cycle.
- The correct energy was supplied to the fitting and recorded by the calibrated control box.
- Extension cords are correct gage and length, if applicable.

### 17.2. **After installation:**

- The fitting remained clamped and free of external stresses until the entire cooling time elapsed.
- No error messages were displayed/stored by the control box.
- No abnormal events were observed during the fusion or cooling cycles.
- Pressure test at 1.5 times the operating pressure was completed and passed.

## 18.0 ASSEMBLY ERROR EXAMPLES

- **Short Stab** – Incorrect Assembly: Assembly errors that can occur include “short-stab” conditions where the one or both of the pipe ends are not centered in the coupling. This condition is avoidable by measuring and marking the stab depth on the pipe ends before inserting them into the coupling. If the pipe ends are not properly inserted, the melt generated during the fusion cycle will expand and flow over the end of the exposed pipe inside the fusion zone. Heating coil wires are carried by the uncontained melt flow, causing shorting and rapid overheating of the fusion zones.

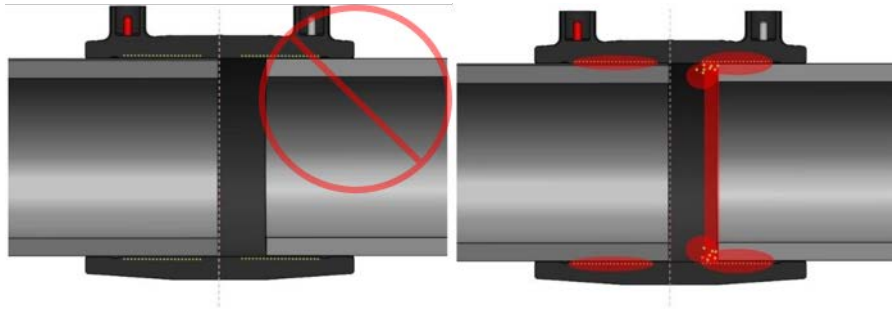

Figure 37: Short Stab - Incorrect Assembly

- **Mis-Stab** – Incorrect Assembly: A mis-stab is another avoidable assembly error where the pipes are not located in the center cold zone of the coupling. In this case, one pipe end is over-inserted into the coupling, while the other is under-inserted. Melt again is allowed to escape between the pipe ends and the potential for heating coil shorting is likely.

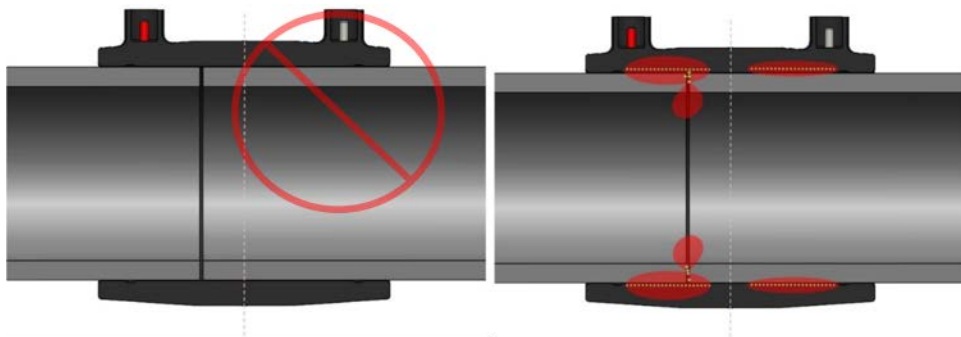

Figure 38: Mis-Stab - Incorrect Assembly

- **Mis-cut** - Another potential error that can cause loss of melt containment is the lack of a square cut on the pipe ends. While it is not necessary, nor practical, that the pipe ends must be cut to exactly 90 degrees, care should be taken to keep the cut as square as possible. Cold zone lengths are designed to accommodate some degree of mis-cut on the pipe ends and still ensure full coverage of the heating wires and sufficient cold zone contact to contain melt flow. A condition where the pipe end is cut at too great an angle to allow the pipe end to cover the heating coil and cold zone is referred to as a “mis-cut” assembly.



Figure 39: Mis-Cut - Incorrect Assembly

## FREQUENTLY ASKED QUESTIONS

### 1. What pipes can be fused with electrofusion fittings?

- Electrofusion fittings are compatible with pipe dimensions conforming to ASTM D2513, F714 and D3035.
- Fittings are typically compatible with pipes with an SDR or DR range of 9 to 17. Other wall thickness ranges and pressure ratings may also apply. Consult the specific fitting manufacturer for details.
- Electrofusion fittings are fusible to PE 2406/2708 and PE3408/3608/3708/3710/4710 pipes.

### 2. What are the power requirements?

A reliable source of AC power is necessary for a successful fusion.

- Generator – well maintained generator meeting the capacity requirements shown in the Table under “POWER REQUIREMENTS”.
  - Generator should have enough fuel to complete the electrofusion cycle.
  - The governor/economy switch should be off so that the throttle is opened all the way in anticipation of the power draw at the start of the fusion cycle.
  - Provide output voltage in the range that meets the specifications of the applicable processor model.
  - Operate within a frequency range of 50 to 60 Hertz.
  - A matching outlet is needed to mate with the plug equipped on the electrofusion processor.

### 3. Can I use an extension cord with my processor?

The use of extension cords should be avoided; in the event an extension cord must be used a 25-foot cord should have a wire gage of #10/3 and a 50-foot cord should have a wire gage of #8/3.

### 4. Can I use a pigtail with my electrofusion processor?

No for field installations

5. What are the most common electrofusion failures?

Electrofusion has proven to be an extremely reliable joining system. The most common reasons for failure account for more than 95% of all fusion failures:

- Contamination – poor pipe preparation
  - Poor, over, or under scraping
- Dirt, mud, dust
  - Grease, oils
  - Moisture
  - Hands (body oil, sunscreen, etc.)
  - Solvents, unsuitable wiping fluids
  - Unclean or unsuitable wiping rags
- Geometry – pipe out of round or not cut square
  - Alignment Errors
    - Pipe Mis-Stab – pipe not cut square and pipe ends not being centered in the cold zone of the fitting.
    - Short Stab – can result from improper insertion of the pipe or movement during weld due to incorrect restraint
    - Excessive Gap – excessive gap between pipe and fitting due to pipe out of roundness, undersized pipe or over scraping of pipe surface.
    - Pipe Movement during Fusion Cycle – due to external forces or forces induced by the welding process, when the pipes are not clamped properly.
- Movement – pipe not properly restrained during fusion process
  - Removal of clamping equipment before observance of minimum cooling times.
- Unusual conditions - Contact EF manufacturers if smoke or melt flow outside the fitting are observed.

6. Can I use sandpaper, dragon skin or emery cloth to clean the PE pipe?

**No**, it is very important to note that abrasive materials such as sand paper, dragon skin or emery cloth should never be used in place of an approved scraping tool. Abrasive materials have been proven to be ineffective in the removal of sufficient amounts to surface material needed to achieve an electrofusion bond and in fact have been shown to impede the electrofusion process.

See “SCRAPER” section of this document.

- ✔ Note the use of wood rasps, metal files or paint scrapers are not considered acceptable.

7. Why does the fitting need to observe the entire cooling time prior to pressure test or backfill?
- One of the most misunderstood and often ignored components of the entire electrofusion process is the cooling phase. It is often assumed that if the fitting is cool enough to touch it must be cool enough to remove the restraint device or even pressure test the connections. The cooling phase is critical to the success of the electrofusion process and careful attention should be given to ensure that the stated cooling times are properly adhered to (refer to fitting manufacturer for specific fitting cooling times).
  - When current is applied to the fitting the plastic in the fitting and on the pipe surface begins to melt and form a melt pool. With continued application of current the melt pool deepens at the pipe and fitting interface which in turn forces internal pressure to build up. After the heating phase, the melt pool re-solidifies. This process is known as co-crystallization between the melted pipe and fitting material. The cooling phase provides a controlled environment between the pipe and fitting where solidification can effectively take place. This cooling phase begins immediately following the termination of current being supplied to the fitting and continues for a period of time beyond the point where the PE polymer re-solidifies (also known as clamping time). This allows ample time for the fusion area to regain the strength and flexibility it exhibited prior to fusion. Any movement or external stresses applied to the fused area during this cooling phase may result in a compromised fusion joint.

8. Do I need to use clamps?

- Electrofusion couplings:

Electrofusion couplings (regardless of manufacturer) require the pipe to be restrained or sufficiently supported on each side of the pipe to restrict movement during the fusion and cooling process and alleviate or eliminate sources of stress and/or strain until both the fusion cycle and the cooling cycle are completed.

To achieve this we recommend the use of some form of pipe restraint and/or support for the primary purpose of controlling and eliminating any movement of the fitting due to fusion pressures generated during the fusion process and/or any external forces exerted on the pipe or fitting. The basis for using pipe restraint and/or support when joining two pieces of PE pipe with an electrofusion coupling is to:

- Minimize potential short stab, mis-stab or binding situations
- Ensure proper cold zone contact with the prepared fusion area so that sufficient interfacial pressure is achieved.
- Eliminate unwanted loss of molten material from the fusion zone

- Electrofusion saddles

Electrofusion saddles fittings include tapping tees, branch saddles, corp saddles and others. Installation of an electrofusion saddle requires the use of recommended restraint systems for the purpose of:

- Holding the fitting in place during the fusion process
- Eliminating fitting movement due to material expansion
- Ensuring proper cold zone contact with the prepared fusion area so that sufficient interfacial pressure is built up.

- ✔ A properly prepared and assembled joint that is kept stationary and free from stresses and strains during the fusion process and recommended cooling time should have good joint integrity that will last for the lifetime of the pipeline.

9. Can electrofusion fittings be re-fused if I have a power related failure?

- Electrofusion fittings can be re-fused only in the event of an input power interruption.
  - Fusion leads were detached during fusion
  - Generator runs out of gas
  - Processor malfunction
  - Other circumstances that results in processor input power interruption
- Recommended procedure for re-fusing fittings:
  1. Fitting should remain in restrained position
  2. Fittings should be allowed to cool to ambient temperature
  3. Fitting should be reconnected to the processor
  4. Fitting should be completely refused for the entire fitting fusion time

⚠ **This re-fusion procedure should be used for fusions that terminated due to input power reasons only. Fittings that fault for any other reason should be removed or abandoned**

## **OPERATOR TRAINING AND QUALIFICATION GUIDELINES**

This guide provides a general introduction to the tools and steps required for making a sound electrofusion joint. It does not take the place of operator training, experience, and qualification through destructive testing. Installers shall complete these requirements prior to installation of electrofusion fittings in a gas distribution system.

The instructions contained in this manual have been qualified to the requirements of Title 49 Code of Federal Regulations, Part 192.283.

Electrofusion fittings shall be installed only by persons that have received training from an authorized instructor, that have a strong working knowledge of polyethylene and heat fusion, and that have demonstrated their understanding of these requirements by making electrofusion joints that have been qualified by destructive testing. Persons responsible for the joining of polyethylene pipe for regulated gas applications must qualify according to the requirements of Title 49 Code of Federal Regulations, Part 192.285. Other regulations may also apply depending on the application, local codes, and/or jurisdictional oversight of state and local regulating agencies.



**49 CFR §192.285 Plastic pipe: Qualifying persons to make joints.**

(a) No person may make a plastic pipe joint unless that person has been qualified under the applicable joining procedure by:

(1) Appropriate training or experience in the use of the procedure; and

(2) Making a specimen joint from pipe sections joined according to the procedure that passes the inspection and test set forth in paragraph (b) of this section.

(b) The specimen joint must be:

(1) Visually examined during and after assembly or joining and found to have the same appearance as a joint or photographs of a joint that is acceptable under the procedure; and

(2) In the case of a heat fusion, solvent cement, or adhesive joint:

(i) Tested under any one of the test methods listed under §192.283(a), or for PE heat fusion joints (except for electrofusion joints) visually inspected and tested in accordance with ASTM F2620-12 (incorporated by reference, see §192.7) applicable to the type of joint and material being tested;

(ii) Examined by ultrasonic inspection and found not to contain flaws that would cause failure; or

(iii) Cut into at least 3 longitudinal straps, each of which is:

(A) Visually examined and found not to contain voids or discontinuities on the cut surfaces of the joint area; and

(B) Deformed by bending, torque, or impact, and if failure occurs, it must not initiate in the joint area.

(c) A person must be re-qualified under an applicable procedure once each calendar year at intervals not exceeding 15 months, or after any production joint is found unacceptable by testing under §192.513.

(d) Each operator shall establish a method to determine that each person making joints in plastic pipelines in the operator's system is qualified in accordance with this section.

(e) For transmission pipe installed after July 1, 2021, records demonstrating each person's plastic pipe joining qualifications at the time of construction in accordance with this section must be retained for a minimum of 5 years following construction.

## SAMPLE WRITTEN REVIEW

The following is a sample written qualification test. Users should modify this test to address their unique operating environment.

Generic Electrofusion Operator Training & Qualification Section

Operator Name: \_\_\_\_\_ Date: \_\_\_\_\_

Location: \_\_\_\_\_

All Questions should be answered with either T for True or F for False.

1. The purpose of scraping is to remove the oxidized layer of PE pipe from the pipe surface prior to electrofusion.
  - a. True
  - b. False
  
2. For out of round pipe it is acceptable to scrape the high points until the pipe fits into the electrofusion coupling.
  - a. True
  - b. False
  
3. Sand paper, dragon skin, emery cloth, and other abrasives are acceptable for scraping.
  - a. True
  - b. False
  
4. If the pipe becomes re-contaminated after scraping it is acceptable to use a suitable solvent for cleaning purposes.
  - a. True
  - b. False
  
5. It is acceptable to perform an electrofusion with a slight trickle of water running across the fusion area.
  - a. True
  - b. False

6. In case of an input power interruption only, an electrofusion fitting can be refused for the entire fusion time after it has been allowed to cool completely.
  - a. True
  - b. False
  
7. Pressurizing, testing, and backfill can be performed immediately after the electrofusion has been completed.
  - a. True
  - b. False
  
8. Pipe ends can be cut to within 10° of being completely square.
  - a. True
  - b. False
  
9. A 2500 watt generator is recommended for fusing electrofusion couplings (12" and smaller).
  - a. True
  - b. False
  
10. Slow drying markers that contain oils should not be used when marking the pipe for scraping.
  - a. True
  - b. False
  
11. If the electrofusion coupling is to be pushed completely over one pipe, it is necessary to scrape the entire length of the coupling onto one of the pipes.
  - a. True
  - b. False
  
12. A standard metal file is acceptable for scraping the pipe surface.
  - a. True
  - b. False
  
13. There is no need to support hanging pipe ends during fusion.
  - a. True
  - b. False
  
14. Operators must re-qualify annually or if they make any bad joint.
  - a. True
  - b. False

15. Observance of pipe print line under saddle fitting fusion area after scraping is acceptable.
- a. True
  - b. **False**
16. A gouge or scratch in the pipe of more than 15% of the wall thickness is acceptable.
- a. True
  - b. **False**
17. An electrofusion joint should not be started if the processor incorrectly identifies the fitting fusion parameters.
- a. **True**
  - b. False
18. Alignment clamps should be used only if the pipes do not line up.
- a. True
  - b. **False**
19. The generator should be checked prior to electrofusion to make sure it is sufficiently fueled .
- a. **True**
  - b. False
20. Electrofusion fittings should be kept in original packaging until installed
- a. **True**
  - b. False

Number Correct: \_\_\_\_\_

Authorized Trainer: \_\_\_\_\_ Date: \_\_\_\_\_